

# WHEEL BRAKE 1637

1,000 kg

## TECHNOLOGY

All AL-KO wheel brakes are ECE-tested and can be connected to the corresponding AL-KO overrun devices (allocation calculation). Install wheel brakes with the correct direction of rotation!  
The brake pads used are free of asbestos!

## SCOPE OF SUPPLY

! (See order overview)  
! Wheel bolts and axle Bowden cables not included in delivery!  
Please order separately

## SURFACE TREATMENT

! Galvanised

## POSSIBLE WHEEL CONNECTIONS

! On request  
! Suitable for rims with centre hole min. 57 mm

Comply with installation guidelines!

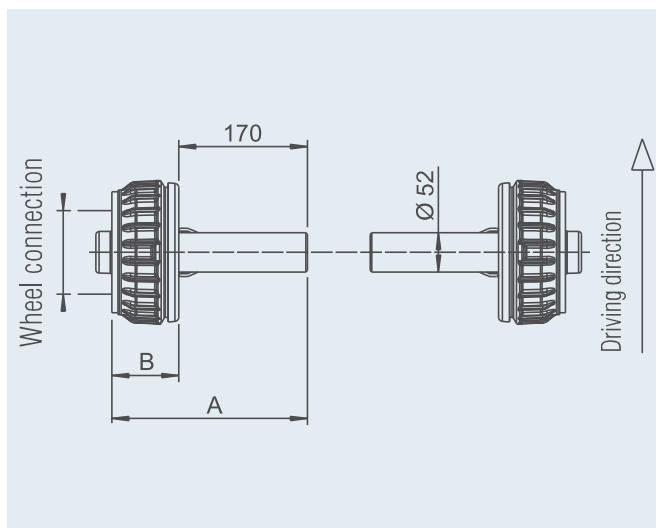

### SAP: RADBREMSE 1637 PAAR EURO

#### Wheel brake 1637 EURO Pair 1000 kg

| Part No. | Wheel load per hub<br>kg | Wheel connection |                   | Offset<br>mm | Dimensions |         | Bearing type | 23 | - | - | 20 |
|----------|--------------------------|------------------|-------------------|--------------|------------|---------|--------------|----|---|---|----|
|          |                          | Connection<br>mm | Thread<br>mm x mm |              | A<br>mm    | B<br>mm |              |    |   |   |    |
| 1225204  | 500                      | 100x4            | M12 x 1.5         | 27-33        | 258        | 88      | Compact      | 23 | - | - | 20 |

#### Wheel brake 1637 EURO Pair 1000 kg watertight

| Part No. | Wheel load per hub<br>kg | Wheel connection |                   | Offset<br>mm | Dimensions |         | Bearing type | 23 | - | - | 20 |
|----------|--------------------------|------------------|-------------------|--------------|------------|---------|--------------|----|---|---|----|
|          |                          | Connection<br>mm | Thread<br>mm x mm |              | A<br>mm    | B<br>mm |              |    |   |   |    |
| 1730615  | 500                      | 100x4            | M12 x 1.5         | 27-33        | 258        | 88      | Compact      | 23 | - | - | 20 |

# WHEEL BRAKE 2051

1,500 kg with stub

## TECHNOLOGY

All AL-KO wheel brakes are ECE-tested (official characteristic value) and can be connected to the corresponding AL-KO overrun devices (allocation calculation).

Install wheel brakes with the correct direction of rotation!

The brake pads used in the wheel brakes are free of asbestos!

## SCOPE OF SUPPLY

- I (See order overview)
- I Wheel bolts and axle Bowden cables not included in delivery! Please order separately

## SURFACE TREATMENT

- I Stub: dip primed black
- I Wheel brake: galvanised
- I Brake drum painted

## POSSIBLE WHEEL CONNECTIONS

- I On request
- I Suitable for rims with centre hole min. 57 mm

4

**Comply with installation guidelines!**

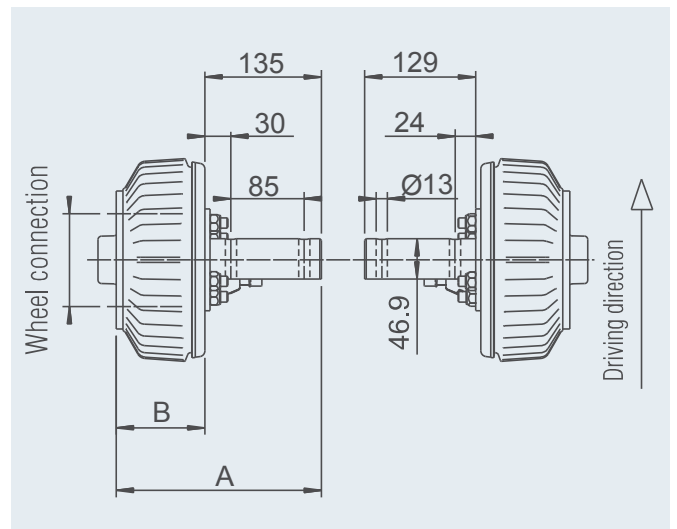

**SAP: RADBREMSE 2051AB PAAR 1500 M STUMMEL**

Wheel brake 2051AB PLUS pair 1500 kg with stub for screwing in

| Part No. | Wheel load per hub<br>kg | Wheel connection |           |        | Dimensions |     | Bearing type | 29.5 | - | 150 | 10 |
|----------|--------------------------|------------------|-----------|--------|------------|-----|--------------|------|---|-----|----|
|          |                          | Connection       | Thread    | Offset | A          | B   |              |      |   |     |    |
| 1225472  | 750                      | 112x5            | M12 x 1.5 | 27-33  | 238        | 103 | Compact      |      |   |     |    |

Wheel brake 2051AB PLUS pair 1500 kg watertight with stub for screwing in

| Part No. | Wheel load per hub<br>kg | Wheel connection |           |        | Dimensions |     | Bearing type | 29.7 | - | 150 | 10 |
|----------|--------------------------|------------------|-----------|--------|------------|-----|--------------|------|---|-----|----|
|          |                          | Connection       | Thread    | Offset | A          | B   |              |      |   |     |    |
| 1225699  | 750                      | 112x5            | M12 x 1.5 | 27-33  | 238        | 103 | Compact      |      |   |     |    |



# WHEEL BRAKE 2361

1,800 kg with stub

## TECHNOLOGY

All AL-KO wheel brakes are ECE-tested (official characteristic value) and can be connected to the corresponding AL-KO overrun devices (allocation calculation).

Install wheel brakes with the correct direction of rotation!

The brake pads used in the wheel brakes are free of asbestos!

## SCOPE OF SUPPLY

! (See order overview)  
! Wheel bolts and axle Bowden cables not included in delivery!  
Please order separately.

## SURFACE TREATMENT

! Galvanised

## POSSIBLE WHEEL CONNECTIONS

! On request  
! Suitable for rims with centre hole min. 57 mm

**Comply with installation guidelines!**

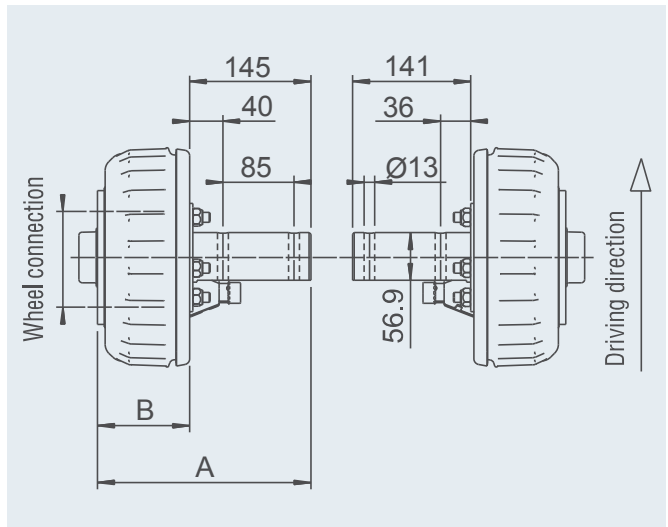

### SAP: RADBREMSE 2361 PAAR 1800 M STUMMEL

#### Wheel brake 2361AB PLUS pair 1800 kg with stub for screwing in

| Part no. | Wheel load per hub<br>kg | Wheel connection |           |        | Dimensions |     | Bearing type | 43.7 | - | 150 | 10 |
|----------|--------------------------|------------------|-----------|--------|------------|-----|--------------|------|---|-----|----|
|          |                          | Connection       | Thread    | Offset | A          | B   |              |      |   |     |    |
| 1225474  | 900                      | 112x5            | M12 x 1.5 | 27-33  | 255        | 114 | Compact      |      |   |     |    |

#### Wheel brake 2361AB PLUS pair 1800 kg watertight with stub for screwing in

| Part no. | Wheel load per hub<br>kg | Wheel connection |           |        | Dimensions |     | Bearing type | 46.2 | - | 150 | 10 |
|----------|--------------------------|------------------|-----------|--------|------------|-----|--------------|------|---|-----|----|
|          |                          | Connection       | Thread    | Offset | A          | B   |              |      |   |     |    |
| 1225700  | 900                      | 112x5            | M12 x 1.5 | 27-33  | 258        | 117 | Compact      |      |   |     |    |

# WHEEL BRAKE 3081A

2,500 kg

## TECHNOLOGY

All AL-KO wheel brakes are ECE-tested and can be connected to the corresponding AL-KO overrun devices (allocation calculation).  
Install wheel brakes with the correct direction of rotation!  
The brake pads used are free of asbestos!

## SCOPE OF SUPPLY

! (See order overview)  
! Wheel bolts and wheel nuts are included in the scope of supply!  
! Axle Bowden cables are not included in the scope of supply!  
Please order separately.

## SURFACE TREATMENT

! Synthetic resin dip-coating black

## POSSIBLE WHEEL CONNECTIONS

! On request  
! Suitable for rims with centre hole min. 161 mm

4

Comply with installation guidelines!

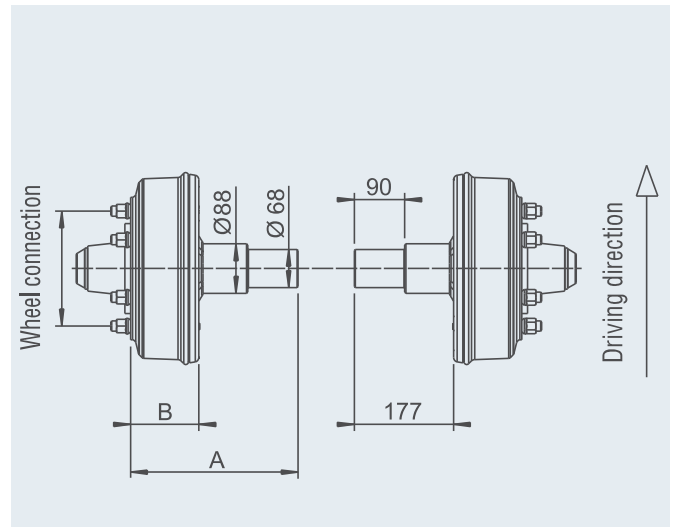

SAP: RADBREMSE 3081A PAAR

Wheel brake 3081 A Pair 2,500 kg

| Part No. | Wheel load per hub<br>kg | Wheel connection |                   | Offset<br>mm | Dimensions |         | Bearing type | 79 | - | - | 20 |
|----------|--------------------------|------------------|-------------------|--------------|------------|---------|--------------|----|---|---|----|
|          |                          | Connection<br>mm | Thread<br>mm x mm |              | A<br>mm    | B<br>mm |              |    |   |   |    |
| 1210552  | 1,250                    | 205x6            | M18 x 1.5         | 0            | 299        | 122     | Taper        | 79 | - | - | 20 |

# BRAKED AXLES

With waterproof bearings 750 to 1,800 kg

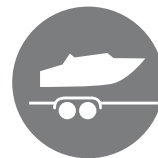

## YOUR ADVANTAGE

- | Compact bearing absolutely watertight due to special seals on both sides
- | Proven in the automotive sector
- | Maintenance-free (lifetime lubrication)
- | Bearing adjustment no longer necessary during servicing
- | The bearing is pressed into the bearing seat of the brake drum with high precision

## ATTENTION!

- | Wheel brakes on the boat trailer must be allowed to cool before driving into the water!
- | Regularly rinse the wheel brakes with clean water after driving into water (especially salt water) and comply with maintenance intervals!

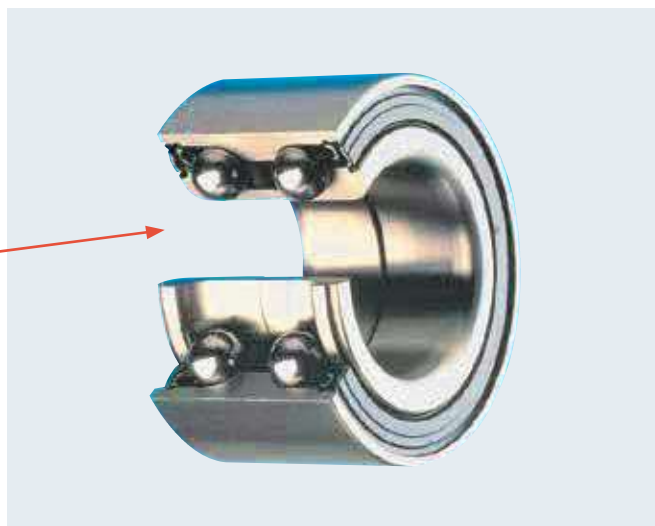

## WATERTIGHT COMPACT BEARINGS

for running axles 750 – 1,800 kg

for braked axles 900 – 1,800 kg

### Versions available

| Unbraked axles            |        |          |          |
|---------------------------|--------|----------|----------|
| Axle load for single axle | 750 kg | 1,500 kg | 1,800 kg |

| Braked axles              |        |          |          |          |          |          |
|---------------------------|--------|----------|----------|----------|----------|----------|
| Axle load for single axle | 900 kg | 1,000 kg | 1,350 kg | 1,500 kg | 1,600 kg | 1,800 kg |
| With wheel brake          | 1637   | 2051 Aa  | 2051 Aa  | 2051 Ab  | 2361     | 2361     |

Visual recognition mark  
**AL-KO WATERPROOF**

