

BRAKE ROD

Brake rod adapter / brake rod holder

SURFACE TREATMENT

I galvanised

SCOPE OF SUPPLY

complete with fixing bolts
(see technical drawing)

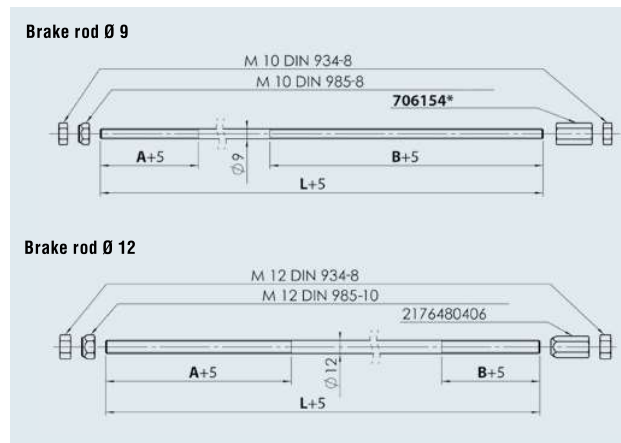

*When using brake rod M10 for tandem, ball nut 2088890006 must also be ordered and exchanged for nut 706154.

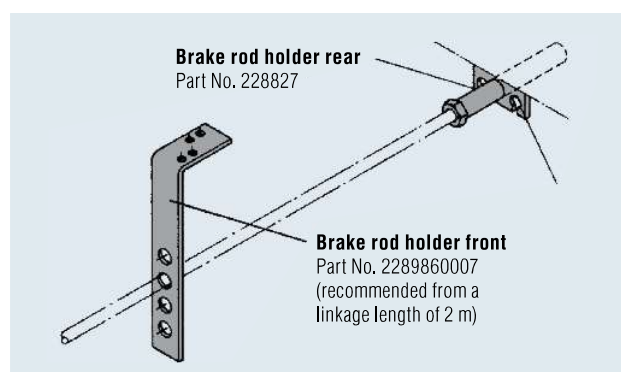

SAP: ZUGSTANGE M10x1550 M MONT

Part No.	Ø	Brake rod / thread	L (mm)	A (mm)	B (mm)	
1733142	Ø 9	M10	1.200	90	430	0,6
1733143	Ø 9	M10	1.400	90	425	0,7
1733144	Ø 9	M10	1.600	90	425	0,8
1733145	Ø 9	M10	1.800	90	425	0,9
1733146	Ø 9	M10	2.000	90	425	1,0
1733147	Ø 9	M10	2.400	90	625	1,3
1733148	Ø 9	M10	2.800	90	625	1,5
1733149	Ø 9	M10	3.285	90	710	1,7
1733150	Ø 9	M10	3.610	90	550	1,9
1733151	Ø 9	M10	4.000	90	615	2,1
1733152	Ø 9	M10	4.500	90	725	2,4
240126	Ø 12	M12	1.975	170	90	1,8
240127	Ø 12	M12	2.450	170	90	2,4
240128	Ø 12	M12	2.950	170	90	3,0
240129	Ø 12	M12	4.000	170	90	4,0

3

SAP: GESTÄNGEADAPTER M12-M10 VERP

Part No.	Brake rod adapter	Perm. gross weight	suitable for
1224412	M12 to M10	up to 2,700 kg	AL-KO overrun devices with M12 rod connection

SURFACE TREATMENT

I Galvanised (front)
I Plastic (rear)

SCOPE OF SUPPLY

(see technical drawing)

SAP: GESTÄNGEHALTER-FÜHRUNG M10

Part No.	Brake rod holder front rear	Brake rod Ø mm	
2289860007	X	Ø 10 and Ø 12	0,2
228827	X	Ø 10	0,1
28867601	X	Ø 12	0,1