

OVERRUN HITCH ZAF 1,0-3

ETI- No. 827007

(Specify the order with the ETI No.)

AL-KO

Spare parts

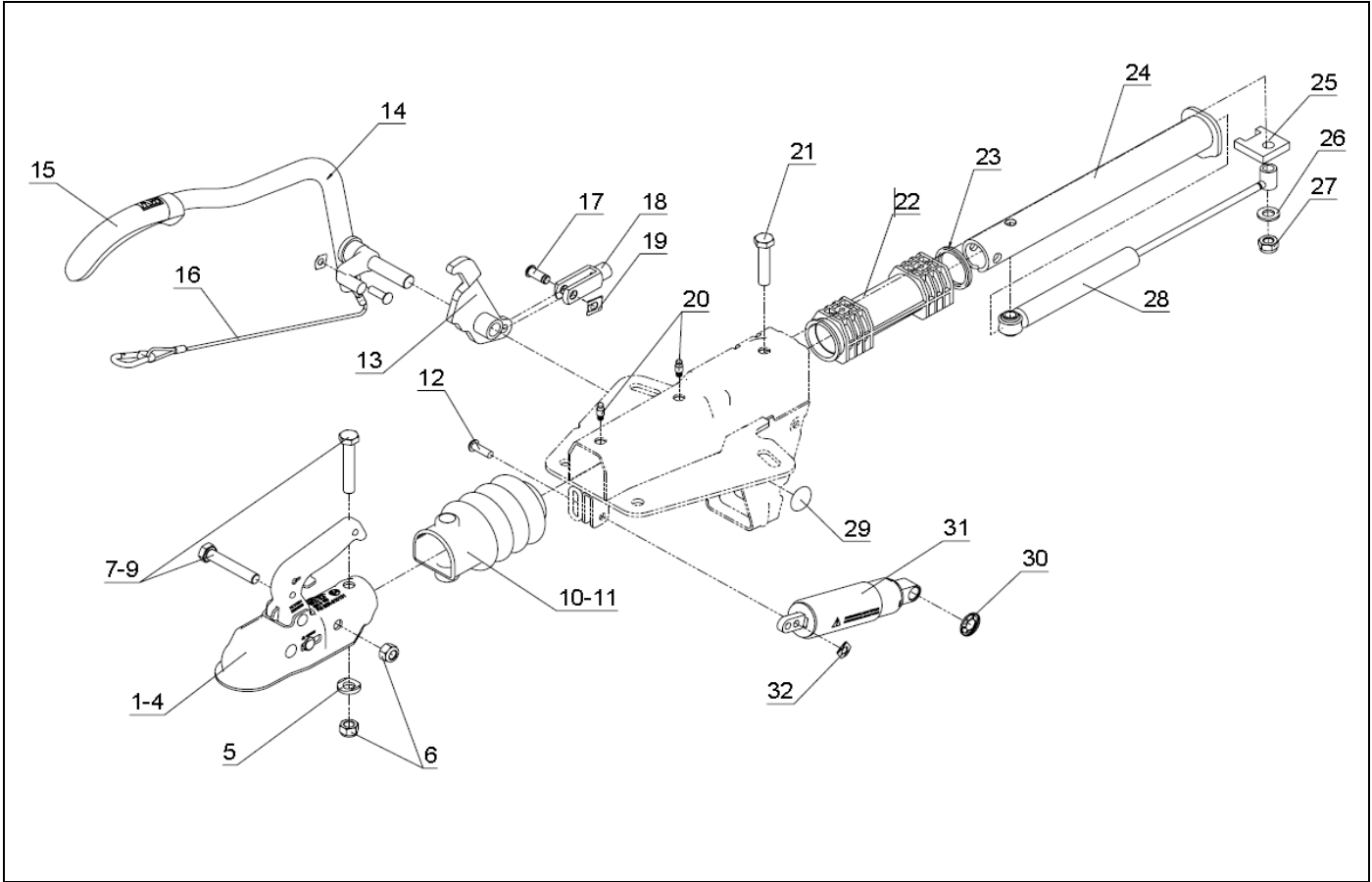

Item	Description	Material-No. (Part-No. BPW-FZT)
1	COUPLIN WW 13-N ASSEMBLY PARTS POS. 5, 6, 7, 10	1860759 (02.1801.59.10)
2	BALL COUPLING ZKB 1,0-1-A (ERSATZ DURCH POS.1)	4014839 (02.1801.10.20)
3	BALL COUPLING ZKAS 1,35-1 ASSEMBLY PARTS POS. 5, 6, 8, 9, 11	1860838 (02.1801.54.20)
4	BALL COUPLING GA=2000KG WW200-B3-H ASSEMBLY PARTS POS. 5, 6, 8, 9, 10	1860812 (02.1801.53.00)
5	LOCKING NUT M12 AS DIN 980 8VZ **	705389 (02.5220.14.82)
6	DISC D=25_13	4016940 (03.320.10.02.0)
7	HEXAGON SCREW M12x70 DIN931 8.8VZ	705418 (02.5021.77.82)
8	HEXAGON SCREW M12x75 DIN931 8.8VZ	705427 (02.5021.78.81)
9	HEXAGON SCREW M12x85 DIN931 8.8VZ	705442 (02.5021.90.82)
10	BELLOW BLUE	4045595 (03.130.09.17.0)
11	BELLOW BLACK	4014800 (02.1011.36.00)
12	BUTTON-HEAD RIVET	4018531 (02.5803.83.06)
13	LEVER	4006879 (05.190.38.94.0)
14	HAND BRAKE LEVER	4017540 (05.203.30.63.0)
15	HANDLE	4018293 (02.1404.19.00)
16	SAFTY CABLE	4018021 (05.327.30.02.0)

Item	Description	Material-No. (Part-No. BPW-FZT)
17	BOLT	4014960 (02.5850.26.02)
18	YOKE	706908 (02.1201.02.12)
19	SL-LOCK	4018315 (02.3301.04.02)
20	GREASE NIPPLE	4018577 (02.6850.23.00)
21	HEXAGON SCREW M12x55 DIN931 8.8 VZ	705430 (02.5021.69.82)
22	BEARING*	4015174 (03.030.30.15.0)
23	RING	4016936 (03.311.20.37.0)
24	PULL TUBE	4018102 (05.399.61.17.0)
25	PLATE, VZ	4016760 (03.293.12.76.0)
26	DISC DIN 125 200HV VZ	706895 (02.5401.13.04)
27	LOCKING NUT M12	705386 (02.5215.14.82)
28	SHOCK ABSORBER	4014936 (02.3722.95.00)
29	LOCKING DISC 16	4018472 (02.5450.84.00)
30	LOCKING DISC 14	4014950 (02.5450.88.00)
31	SPRING BRAKE	4018081 (05.397.68.65.0)
32	LOCK	706972 (02.3301.03.02)

* ATTENTION: AFTER INSTALLATION OF THE BUSHES THE INNER DIAMETER MUST BEI REAMED TO PARTICULAR SIZE OF THE DRAW TUBE.

** FOR SAFETY REASONS: SELF-LOCKING NUT AND SCREW WITH CHEMICAL / MECHANICAL SELF-LOCKING MUST BE USED ONCE. AFTER UNTIGHTEN ALWAYS USE A NEW SPARE.

provided	ETI-No.	changed	Change No.	Reason of the change	Revisions-No.
31.01.18 J.B.	827007_en				