





OVERRUN DEVICE V AND SQUARE STEEL

with lowering handbrake lever; 950 to 3,000 kg

SAP: AE KPL VKT 70 AK161 TOTP

Overrun device square 161 S with AK 161

Part no.	Type	Gross weight in kg	Nose load in kg	Version of drawbar installation	Change-over relay lever?	Can be combined with AL-KO wheel brake	Hitch mounted				
1 253 083	161 S	950 – 1,600	100	Square 70	Yes	2051 / 2361	AK 161	17	–	15	20

SCOPE OF DELIVERY

- I Overrun device (see illustration)
- I Plug holder (loose)
- I Instructions for use (loose)

ECE test report no.

Overrun device: 361-0047-97



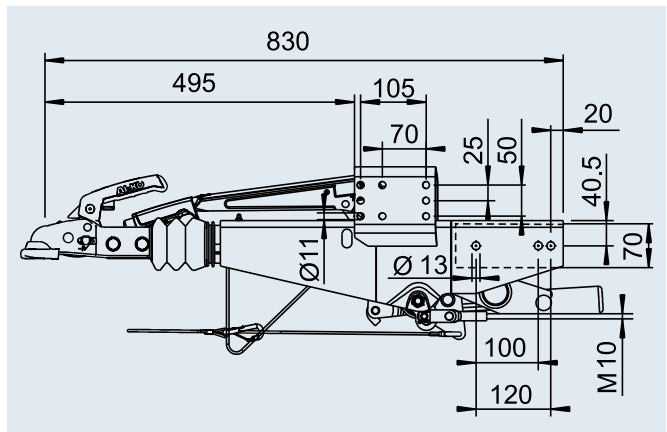

ECE type approval no.

Drawbar installation: E1 55R-01 0267



SAP: AE KPL V OB AK161 TOTP

Overrun device V 161 S with AK 161 and 251 G with AK 301

Part no.	Type	Gross weight in kg	Nose load in kg	Version of drawbar installation	Change-over relay lever?	Can be combined with AL-KO wheel brake	Hitch mounted				
1 253 076	161 S	950 – 1,600	100	top	Yes	2051 / 2361	AK 161	14	–	15	20
1 251 332	251 G	1,550 – 3,000	120	top	Yes	3062 / 3081	AK 301	19	–	15	20

SCOPE OF DELIVERY

- I Overrun device (see illustration)
- I Plug holder (loose)
- I Instructions for use (loose)

ECE test report no.

Overrun device: 361-0047-97

ECE type approval no.

Drawbar installation: E1 55R-01 0227

