





FRENO A REPULSIONE QUADRO

senza timone 950 - 1.600 kg

SAP: AE KPL VKT 70 161S AK161 GASF

AE VKT 161S – VKT 70 con AK 161 e Soft-Dock

Cod. art.	Tipo	Portata complessiva in kg	Carico d'appoggio in kg	Misura B ∅ mm	Leva di rinvio reversibile?	Combinabile con freno ruota AL-KO	Gancio montato				
1 251 904	161S	950 – 1.600	100	70	no	1636G/1637/2051	AK 161	15	–	40	2
1 251 905	161S	950 – 1.600	100	70	no	2361	AK 161	15	–	40	2



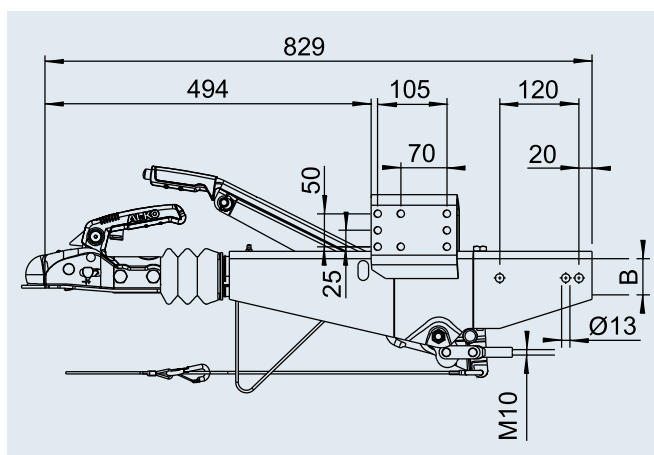

Freno a repulsione: 361-0047-97

Carcassa repulsore: E1 55R-01 0267



SAP: AE KPL VKT 100 161S AK161 GASF

AE VKT 161S – VKT 100 con AK 161 e Soft-Dock

Cod. art.	Tipo	Portata complessiva in kg	Carico d'appoggio in kg	Misura B ∅ mm	Leva di rinvio reversibile?	Combinabile con freno ruota AL-KO	Gancio montato				
1 251 906	161S	950 – 1.600	100	100	sì	1637/2051	AK 161	16	–	40	2
1 251 907	161S	950 – 1.600	100	100	sì	2361	AK 161	16	–	40	2

Freno a repulsione: 361-0047-97

Carcassa repulsore: E1 55R-01 0267

