





FRENO A REPULSIONE QUADRO

senza timone 1.500 - 2.600 kg

SAP: AE KPL VKT 100 251S AK270 GASF

AE VKT 251S con AK 270 e Soft-Dock

Cod. art.	Tipo	Portata complessiva in kg	Carico d'appoggio in kg	Misura B ∅ mm	Leva di rinvio reversibile?	Combinabile con freno ruota AL-KO	Gancio montato				
1 251 908	251S	1.500 – 2.600	100	100	sì	1637/2051	AK 270	20	–	25	2
1 251 909	251S	1.500 – 2.600	100	100	sì	2361	AK 270	20	–	25	20

N. verbale di approvazione ECE

Freno a repulsione: 361-0044-97



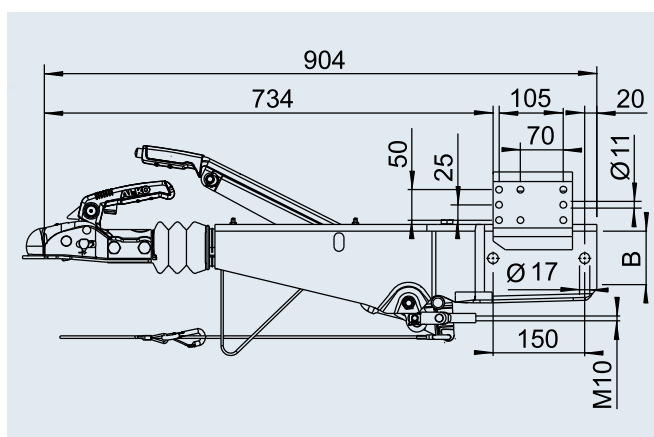

N. approvazione ECE

Carcassa repulsore: E1 55R-01 0268



SAP: AE KPL VKT 100 251S DINÖSE GASF

AE VKT 251S con golfare DIN

Cod. art.	Tipo	Portata complessiva in kg	Carico d'appoggio in kg	Misura B ∅ mm	Leva di rinvio reversibile?	Combinabile con freno ruota AL-KO	Gancio montato				
240 010	251S	1.500 – 2.600	100	100	sì	1637/2051	golfare DIN	21	–	25	20
242 960	251S	1.500 – 2.600	100	100	sì	2361	golfare DIN	21	–	25	20

N. verbale di approvazione ECE

Freno a repulsione: 361-0044-97

N. approvazione ECE

Carcassa repulsore: E1 55R-01 0268

