

AXLE RIGID BRAKED 2051Ab EA 1500 KG TOP ASSEMBLY

ETI- No. 811773

(Specify the order with the ETI No.)

AL-KO
Spare Parts

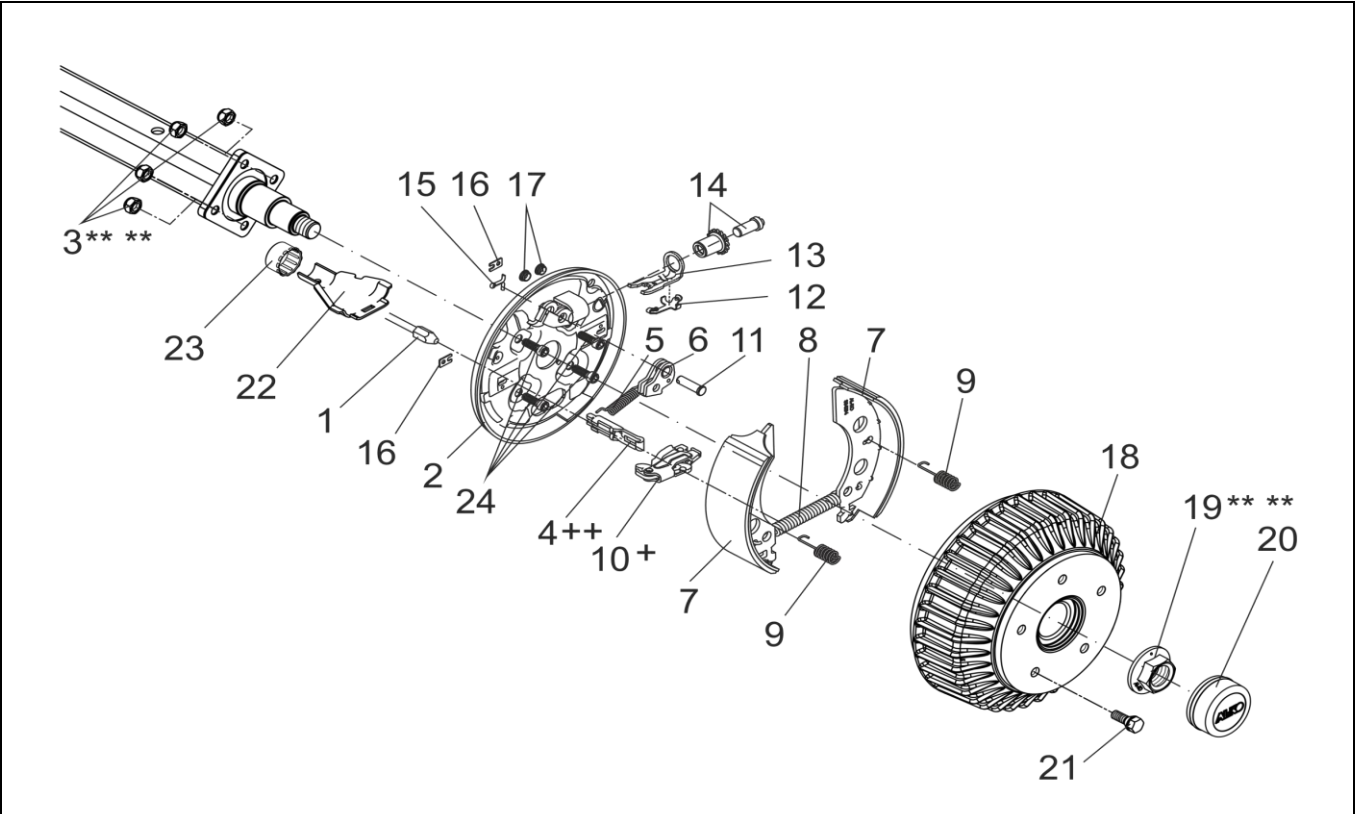

Item	Description	Part No.
1	MOUNTABLE BOWDEN CABLE 350 / 546 LONG	247281
	530 / 726 LONG	247282
	770 / 966 LONG	247283
	890 / 1086 LONG	247284
	1020 / 1216 LONG	247285
	1130 / 1326 LONG	247286
	1320 / 1516 LONG	247287
	1430 / 1626 LONG	247288
	1620 / 1816 LONG	247289
	1790 / 1986 LONG	247290
2	BRAKING PLATE LEFT 2051	691048
	RIGHT 2051	691049
3	HEX NUT DIN 985-M12-10-ZN8DISP ** **	705526
4	CONNECTION EYE ++	604262
5	TENSION SPRING	2187370003
6	AUTO-REVERSE LEVER LEFT	571386
	RIGHT	571387
7	SET BRAKE JAW FOR AXLE INCL (COVER PLATE,TENSION SPRING,PRESSURE SPRING)	1213889

Item	Description	Part No.
8	TENSION SPRING	2082000007
9	PRESSURE SPRING	2088800003
10	SPREAD HINGE LOCK 2051 +	571510
11	BEARING BOLT	368651
12	COMPOUND SPRING	368405
13	BOW PRESSURE	368361
14	ADJUSTING SCREW AND THE ADJUSTING NUT	21873708
15	SPLINT PIN DIN 94 4X20-VZ	700192
16	COVER PLATE	2382610002
17	STOPPER	373245
18	BRAKE DRUM COMPLETE WITH BEARINGS Ø112X5 M12X1.5 UP TO 650KG	586450
	SPARE PARTS SET: 1X BEARING, 1X CIRCLIP, 1X FLANGE NUT	1224803
19	FLANGE NUT M24X1.5	581200
20	END CAP Ø57	581197
21	WHEEL BOLT SPHERIC M12x1,5	2081670020
	CONUS M12X1.5	2081670018
22	CUP	371387
23	PROTECTIVE CAP	371389
24	CYLINDER BOLT WITH HEXAGON SOCKET DIN 6912-M12X40-8.8-ZN8DISP	706622

+ THE CENTRE OF ROTATION OF THE BRAKE LEVER MUST BE FIXED ON THE SAME SIDE AS THE BOLT OF THE AUTO-REVERSE.
 ++ THE OPEN SIDE OF THE CONNECTION EYE FOR THE BOWDEN CABLE MUST SHOW TO THE CENTRE OF ROTATION OF THE BRAKE LEVER.

** WHEN ORDERING PLEASE INDICATE SIZE A AND B!

*** FOR SAFETY REASONS: SELF-LOCKING NUT AND SCREW WITH CHEMICAL SELF-LOCKING MUST BE USED ONCE. AFTER UNTIGHTEN ALWAYS USE A NEW SPARE.

THE RETAIL OF INDIVIDUAL BRAKE SHOES IS NOT PERMITTED BY EU DIRECTIVE FROM 1st OF OCTOBER 2002.
 ATTENTION: THE SET INCLUDES FOUR BRAKE SHOES AND THE APPENDANT TENSION SPRINGS, PRESSURE SPRINGS AND COVER PLATES.

provided	ETI-No.	changed	Change No.	Reason of the change	Revisions-No.
17.08.15ÖJ	811773_en		FREIGABE		A