

OVERRUN DEVICE V 44 V DIN-DRAWBAR EYE WITHOUT HANDBRAKELEVER



ETI- No. 811648

(Specify the order with the ETI No.)

Spare Parts

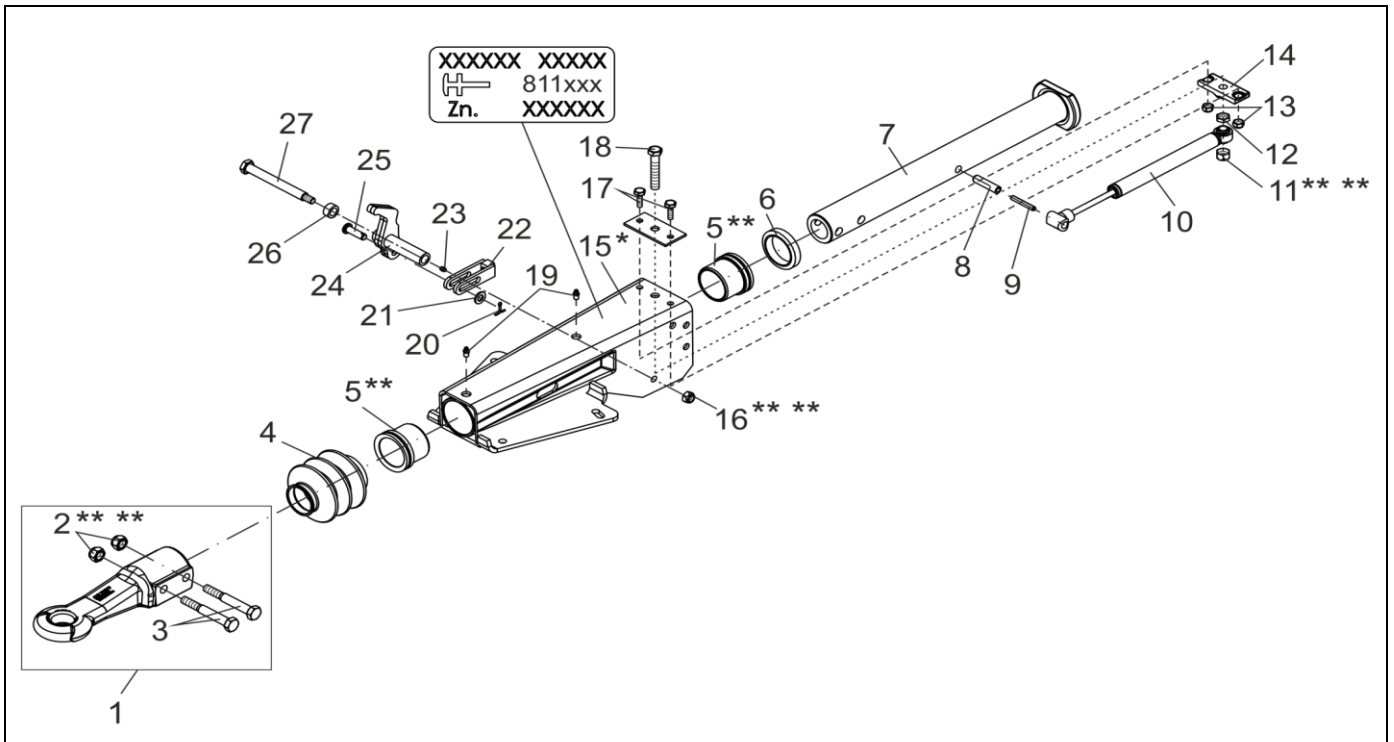

Item	Description	Part No.
1	DRAWBAR EYE DIN Ø40 INCL. (POS.2,3)	1225780
2	HEX NUT DIN 985-M16-8.8-A3C ** **	704089
3	HEX BOLT DIN 931-M16X110-8.8-A3C	703795
4	BELLOWS	21726605
5	BUSH **	2172660004
6	PROFILE RING	2172660003
7	DRAW TUBE	1351222
8	CLAMPING PIN DIN 1481-14X55	702371
9	CLAMPING PIN DIN 1481-8X55	702369
10	SHOCK ABSORBER	372854
11	HEX NUT DIN 980-V M14-8-A3C ** **	704067
12	HEX NUT DIN 439-M14-04-A3C	701854
13	HEX NUT DIN 985-M10-10-A3C	700122
14	END STOP PLATE	21783404

Item	Description	Part No.
15	HOUSING	*
16	HEX NUT DIN 985-M12-10-A3C ** **	702750
17	HEX BOLT DIN 933-M10X30-8.8-A3C	702130
18	HEX BOLT DIN 933-M14X80-8.8-A3C	701514
19	GREASE NIPPLE CONUS DIN 71412-AS 8X1	375900
20	SPLINT PIN DIN 94-3.2X20-A3C	702004
21	WASHER DIN125-A13-A3C	700140
22	FORK HEAD	21783407
23	GREASE NIPPLE CONUS DIN 71412-AS 6X1	700203
24	BELL CRANK (INCL. GREASE NIPPLE CONUS)	387958
25	BOLT DIN 1444-12X40X34.5-EN2	702857
26	BUSH	353140
27	BEARING BOLT	649187

* ONLY COMPLETE OVERRUN DEVICE AVAILABLE, SEE IMPRINT ZN.-NR.

** ATTENTION: AFTER FITTING THE BEARING BUSHES MUST BE REAMED TO THE PARTICULAR DRAW BAR DIAMETER!

*** FOR SAFETY REASONS: SELF-LOCKING NUT AND SCREW WITH CHEMICAL SELF-LOCKING MUST BE USED ONCE. AFTER UNTIGHTEN ALWAYS USE A NEW SPARE.

provided	ETI-No.	changed	Change No.	Reason of the change	Revisions-No.
09.07.12 ÖJ	811648_en		FREIGABE		A
		30.10.2012/ÖJ	17165	Pos.14 was 1540195	B