

# SEMI EJES SIN FRENO

750 kg / 112x5 estancos y 1.000 kg / 100x4



## TRATAMIENTO DE LA SUPERFICIE

I Cuerpo de eje galvanizado en caliente

## COMPOSICIÓN DE ENTREGA

- I Pernos de rueda sueltos
- I Instrucciones de operación

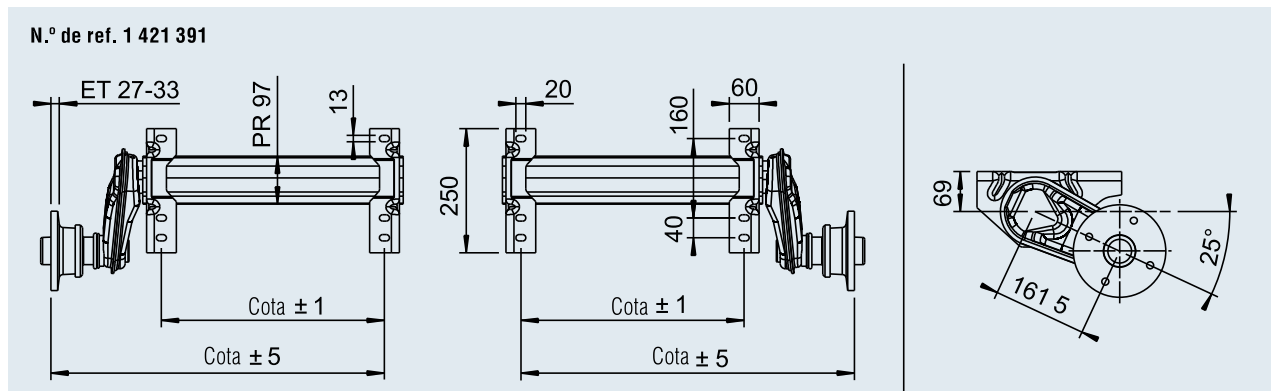
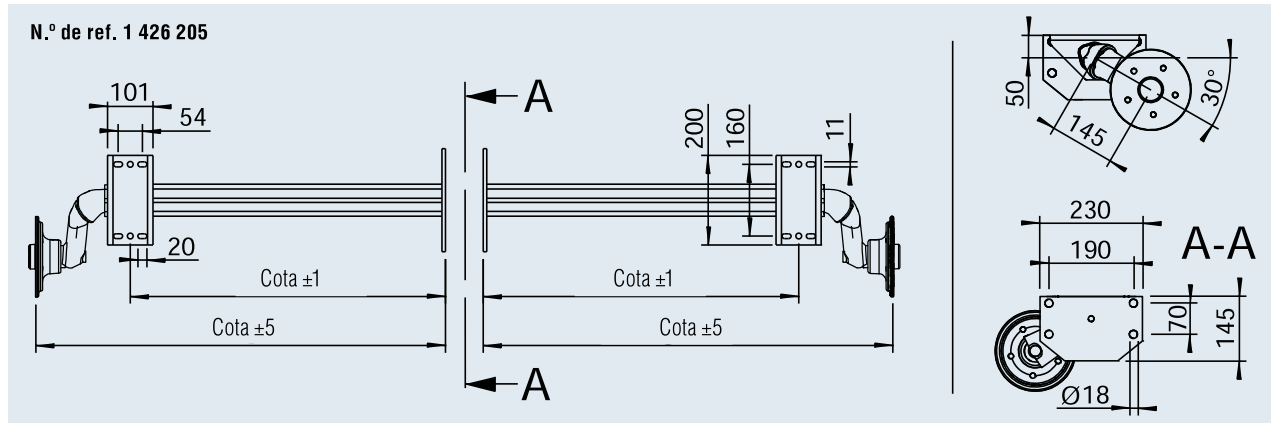
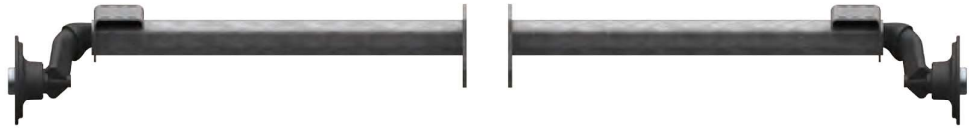

SAP: ACHSE GU UBR HA 750 OPTIMA WD

N.º de ref.	Carga por eje por cada par kg	Tipo	Estanco	Freno de rueda	Ataque	Cota mm	Cota mm				
1 426 205	750	750-5	sí	no	112x5	703	913	33	-	30	10
1 421 391	1.000	1000-3	no	no	100x4	450	673	37	-	30	10