

DEMI-ESSIEUX FREINÉS

1 300 kg / 112 x 5 et 1 500 kg / 112 x 5



CONTENU DE LA LIVRAISON

- | Arrêt de gaine essieu solo en vrac
- | Palonnier essieu solo en vrac
- | Câbles de frein en vrac
- | Vis de roue en vrac

TRAITEMENT DE SURFACE

- | Corps d'essieu galvanisé

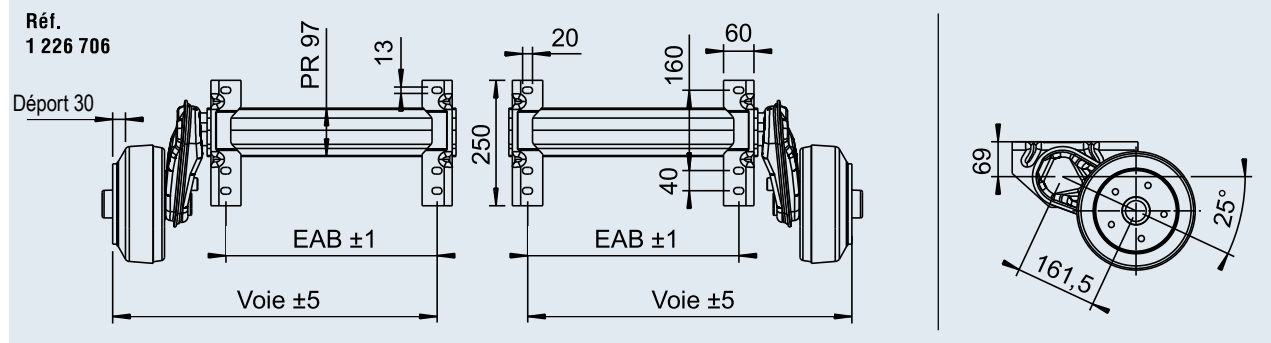
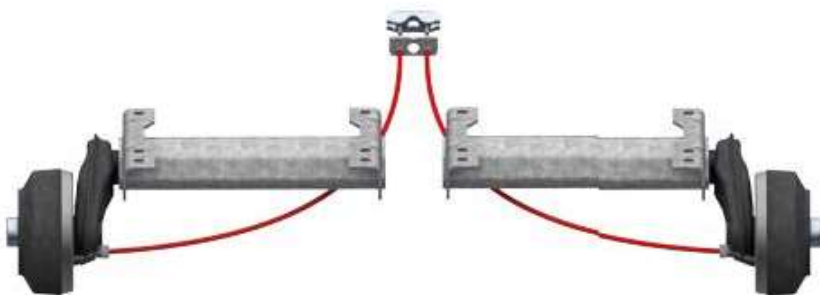
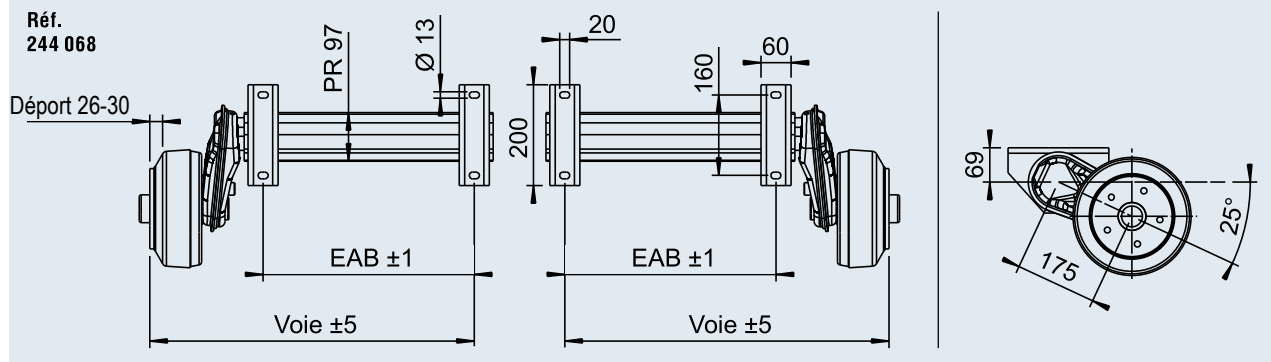
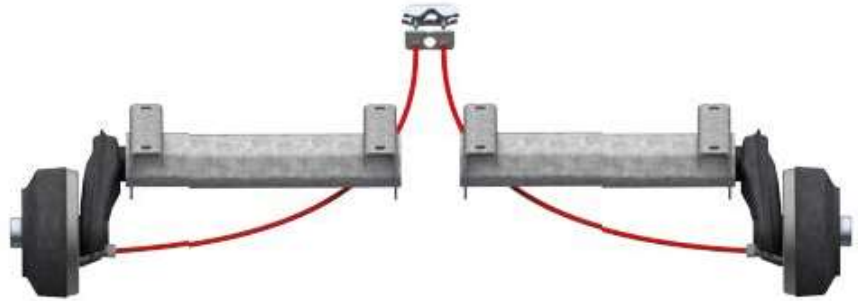

SAP: EURO1ACHSE GRM GLL HA1300

Réf.	Charge à l'essieu par paire kg	Type	Frein de roue	Perçage	EAB en mm	Voie en mm				
244 068	1 300	B 1200-5	2051 vers. A	112x5	420	700	51	-	30	10
1 226 706	1 500	B 1200-5	2051 vers. A	112x5	420	645	49	-	30	10

DEMI-ESSIEUX FREINÉS

1 800 kg / 112x5 et 2 500 kg / 205x6



CONTENU DE LA LIVRAISON

- ▮ Arrêt de gaine essieu solo en vrac
- ▮ Palonnier essieu solo en vrac
- ▮ Câbles de frein en vrac
- ▮ Vis de roue en vrac

TRAITEMENT DE SURFACE

- ▮ Corps d'essieu galvanisé

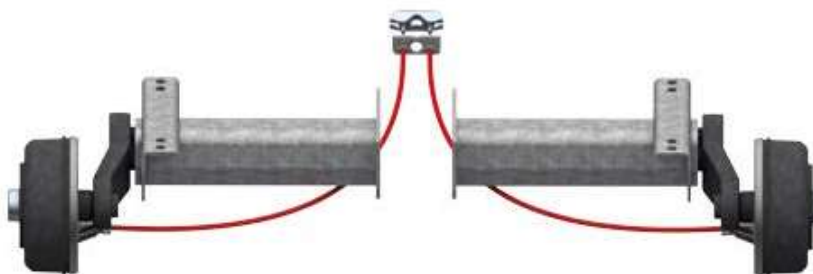

4

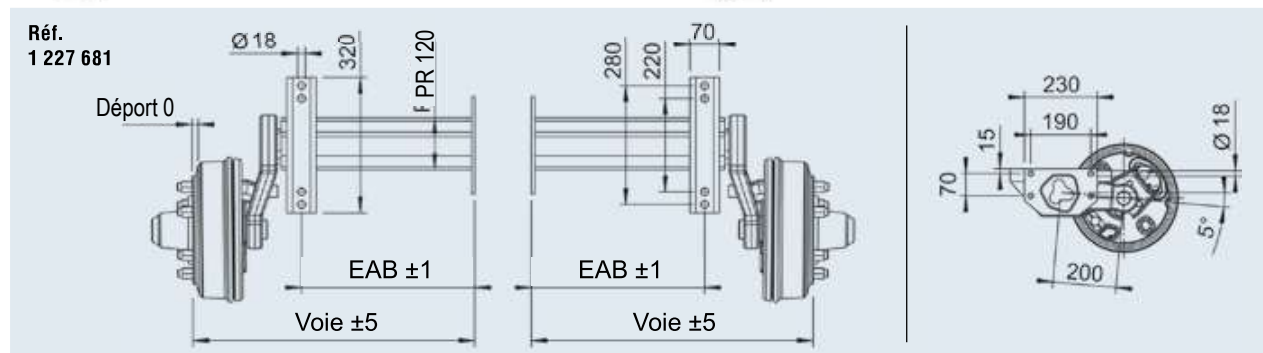
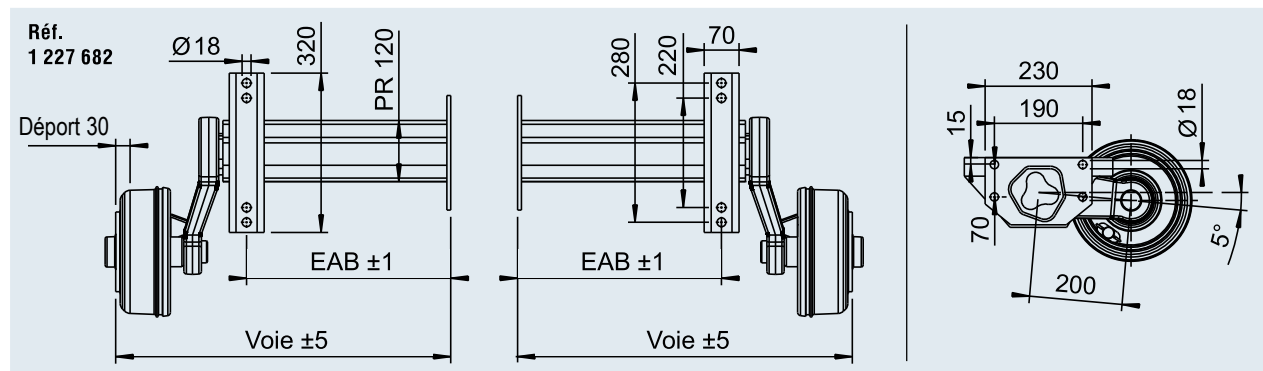

SAP: ACHSE GU LN GS GRM EA1800

Réf.	Charge à l'essieu par paire kg	Type	Frein de roue	Perçage	EAB mm	Voie mm				
1 227 682	1 800	B 2000-0	2361	112x5	410	673	92	-	30	10
1 227 681	2 500	B 2500-8	3062	205x6	410	668	108	-	30	10