

# WHEEL BRAKE EURO1 2051 TYPE A UP TO 650 KG

ETI- Nr. 811294

(Specify the order with the ETI No.)

**AL-KO**  
Spare Parts

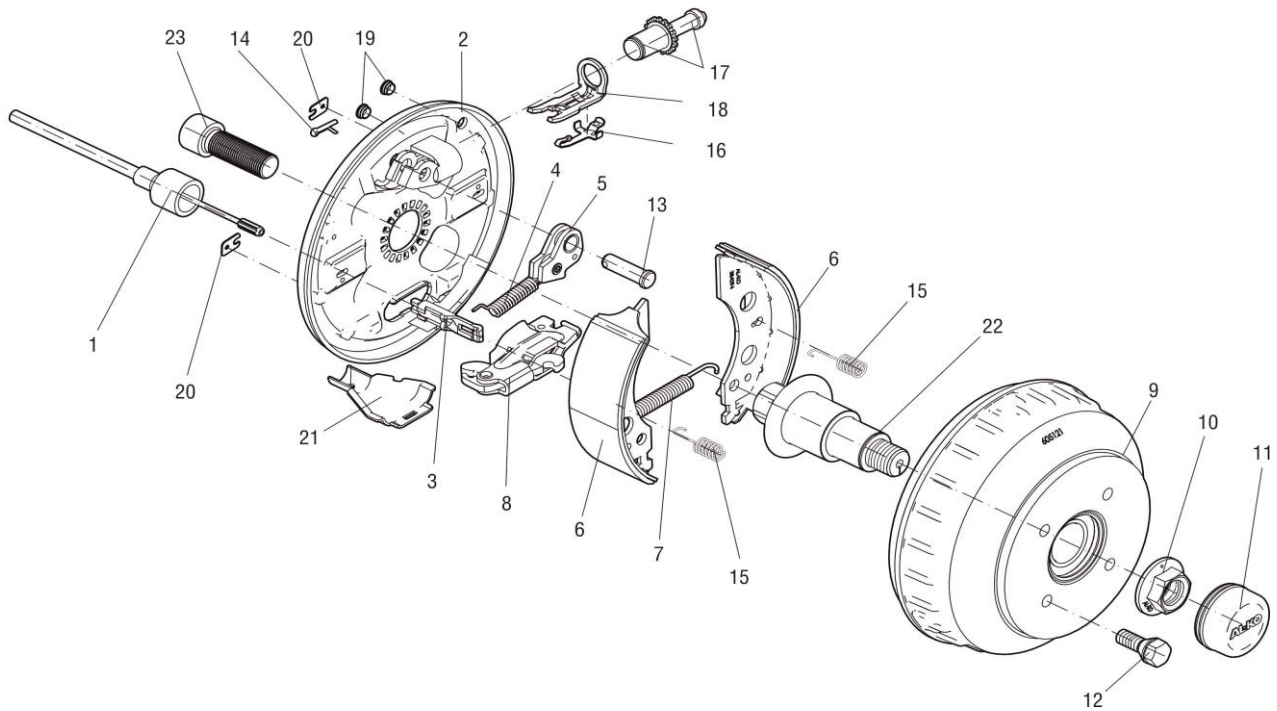

Item	Description	Part-No.	
1	MOUNTABLE BOWDEN CABLE	350 / 546 LONG	247281
		530 / 726 LONG	247282
		770 / 966 LONG	247283
		890 / 1086 LONG	247284
		1020 / 1216 LONG	247285
		1130 / 1326 LONG	247286
		1320 / 1516 LONG	247287
		1430 / 1626 LONG	247288
		1620 / 1816 LONG	247289
		1790 / 1986 LONG	247290
2	BRAKING PLATE LEFT 2051 A RIGHT 2051 A	571376	
		571377	
3	CONNECTION EYE	++	604262
4	TENSION SPRING		2187370003
5	AUTO-REVERSE LEVER LEFT RIGHT	571386	
		571387	
6	SET BRAKE JAW FOR AXLE INCL (COVER PLATE, TENSION SPRING, PRESSURE SPRING)		1213889
7	TENSION SPRING		2082000007
8	SPREAD HINGE LOCK 2051	+	571510
9	BRAKE DRUM COMPLETE WITH BEARINGS	Ø98X4 M12X1.5 UP TO 650KG 160MM MOUNTING FACE	573191
		Ø100X4 M12X1.5 160MM MOUNTING FACE	573192
		Ø112X5 M12X1.5 160MM MOUNTING FACE	573193
		Ø139,7X4 M12X1.5 180MM MOUNTING FACE	578826
		Ø140X5 M14X1.5 180MM MOUNTING FACE	578825
SPARE PARTS SET: 1X BEARING, 1X CIRCLIP, 1X FLANGE NUT			1224803

Item	Description	Part-No.	
10	FLANGE NUT M24X1.5	*** **	581200
11	END CAP Ø57		581197
12	WHEEL BOLT CONUS M12X1.5 SPHERIC M12x1,5 SPHERIC M12x1,5 (R13) CONUS M14X1.5		2081670018
			2081670020
			372138
			603357
13	BEARING BOLT		368651
14	SPLINT PIN DIN 94 4X20-VZ		700192
15	PRESSURE SPRING		2088800003
16	COMPOUND SPRING		368405
17	ADJUSTING SCREW AND THE ADJUSTING NUT		21873708
18	BOW PRESSURE		368361
19	STOPPER		373245
20	COVER PLATE		2382610002
21	CUP		371387
22	STUB AXLE UP TO 1500 KG		643044
23	CYLINDER BOLT WITH HEXAGON SOCKET	*** **	704096

+ THE CENTRE OF ROTATION OF THE BRAKE LEVER MUST BE FIXED ON THE SAME SIDE AS THE BOLT OF THE AUTO-REVERSE.

++ THE OPEN SIDE OF THE CONNECTION EYE FOR THE BOWDEN CABLE MUST SHOW TO THE CENTRE OF ROTATION OF THE BRAKE LEVER.

\*\*\* FOR SAFETY REASONS: SELF-LOCKING NUT AND SCREW WITH CHEMICAL SELF-LOCKING MUST BE USED ONCE. AFTER UNTIGHTEN ALWAYS USE A NEW SPARE.

THE RETAIL OF INDIVIDUAL BRAKE SHOES IS NOT PERMITTED BY EU DIRECTIVE FROM 1st OF OCTOBER 2002.  
ATTENTION: THE SET INCLUDES FOUR BRAKE SHOES AND THE APPENDANT TENSION SPRINGS, PRESSURE SPRINGS AND COVER PLATES.

provided	ETI-No.	changed	Change No.	Reason of the change	Reasons-No.
19.01.00	811294_en	10.12.2009	FREIGABE		A
		14.02.2011 HI	16422	see change notice	B