

ASSALE RIGIDO SFRENATO 750 KG PLUS

98x4 e 100x4



TECNICA

Modello: PLUS
 Tipo di assale: LS 750
 Portata per assale: EA 750 kg
 Attacco ruota: 98x4 / 100x4

FORNITURA

I Colonnelle ruota sciolte

TRATTAMENTO SUPERFICIE

I Profilo assale zincato a caldo





ACCESSORI

I vedi pagine seguenti

Osservare le linee guida di montaggio!



SAP: ACHSE STARR UBR EA 750

Larghezza complessiva in mm	Larghezza ai supporti in mm	Assale singolo con attacco ruota 98x4 STARR UBR PLUS LS 750	Assale singolo con attacco ruota 100x4 STARR UBR PLUS LS 750				
		Colonnelle ruote cono M 12x1,5 Assale compl.	Colonnelle ruote cono M 12x1,5 Assale compl.				
1.130	700	200 571 01	200 571 49	15,0	-	50	15
1.180	750	200 571 02	200 571 50	15,5	-	50	15
1.230	800	200 571 03	200 571 51	15,5	-	50	15
1.280	850	200 571 04	200 571 52	16,0	-	50	15
1.330	900	200 571 05	200 571 53	16,0	-	50	15
1.380	950	200 571 06	200 571 54	16,5	-	50	15
1.430	1.000	142 155 9	142 152 1	17,0	-	50	15
1.480	1.050	200 571 07	200 571 55	17,0	-	50	15
1.530	1.100	200 571 08	200 571 56	17,5	-	50	15
1.580	1.150	200 571 09	200 571 57	17,5	-	50	15
1.630	1.200	200 571 10	200 571 58	18,0	-	50	15
1.680	1.250	200 571 11	200 571 59	18,0	-	50	15
1.730	1.300	200 571 12	200 571 60	18,5	-	50	15
1.780	1.350	200 571 13	200 571 61	19,0	-	50	15
1.830	1.400	200 571 14	200 571 62	19,0	-	50	15
1.880	1.450	200 571 15	200 571 63	19,5	-	50	15
1.930	1.500	200 571 16	200 571 64	20,0	-	50	15
1.980	1.550	200 571 17	200 571 65	20,0	-	50	15
2.030	1.600	200 571 18	200 571 66	20,5	-	50	15
2.080	1.650	200 571 19	200 571 67	20,5	-	50	15
2.130	1.700	200 571 20	200 571 68	21,0	-	50	15
2.180	1.750	200 571 21	200 571 69	21,0	-	50	15
2.230	1.800	200 571 22	200 571 70	21,5	-	50	15
2.280	1.850	200 571 23	200 571 71	22,0	-	50	15
2.330	1.900	200 571 24	201 571 72	22,0	-	50	15

Senso di marcia

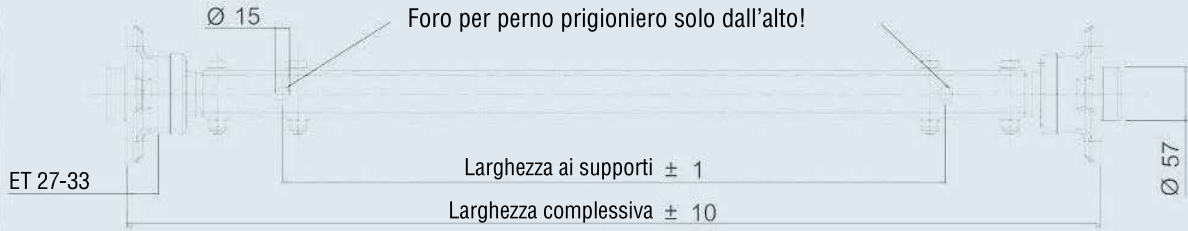

4

Coppia di serraggio della vite
M12X1.25X70-10.9 DIN 931:
 150 ± 5 Nm

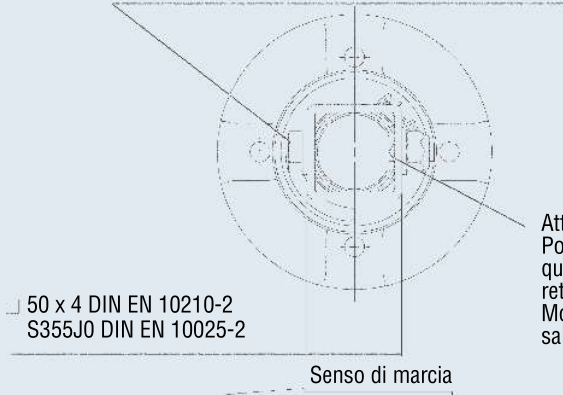

Attenzione:
Posizionare la saldatura del tubo
quadrato nella direzione di marcia sul
retro!
Montare la fresatura del fusello sulla
saldatura del tubo quadrato!

